

FORTEX



ООО НПО ФОРТЭК
Украина.
тел. - 048 7012122
тел. - 056 7885050
тел. - 062 3285535
e-mail: info@fortex.in.ua
www.fortex.in.ua

V SERIES
ENGLISH



Series
HEAVY CUTTING

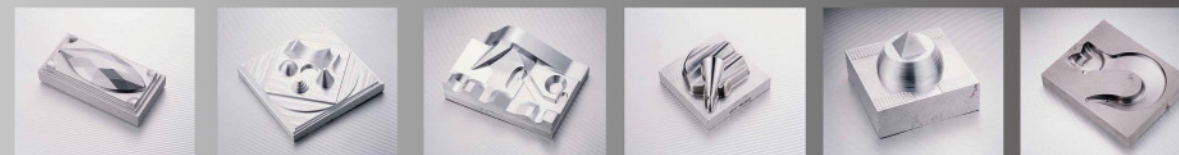

TAKUMI MACHINERY CO., LTD

Headquarter
No.50, 35th, Taichung Ind. Park, Taichung, Taiwan 407
Tel: +886-4-2358-3838
Fax: +886-4-2358-0176
Website : www.takumi.com.tw
E-mail : sale-os@takumi.com.tw

Taipei Office
No.7, Lane 49, Mingde St., Sinjhuang Dist., New Taipei City.
Tel: +886-2-8991-2811
Fax: +886-2-2993-1639

Takumi Machinery (Kunshan) Co., Ltd.
No. 3069, Pei Men Rd., Yushan Town, Kunshan City
215300, China
Tel: +86-512-8260-8008
Fax: +86-512-8260-8009

Vertical Machining Center

- ◆ Bed 4/6 box ways design
- ◆ Heavy Cutting
- ◆ High Stability



www.takumi.com.tw

V SERIES

**The achievement of Takumi's innovation and technology:
The perfect performance of heavy cutting and high stability.**

V series is designed for the machining requirements from the industries of parts production and mold & die. 3 axes are equipped with box ways. The wider supporting space and high loading capacity of box ways provide the best rigidity and stability.

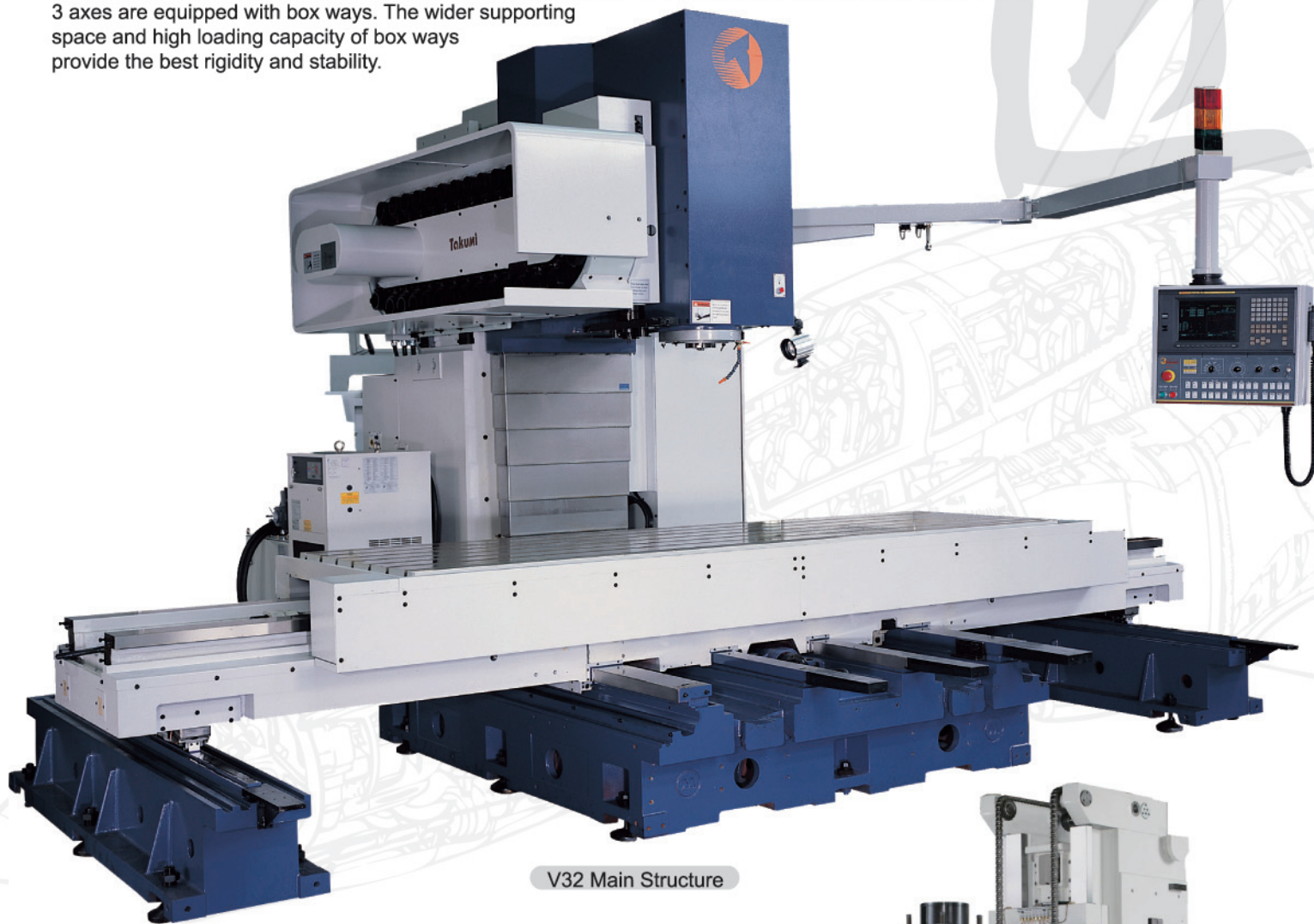

V32 Main Structure



V10 Four Box Way



V10 Main Structure

High Efficiency Cutting Performance

V11 Gear type spindle /BT50 /6000rpm /Fanuc α8 / 11kW(Optional) Material : S45C (unit: mm)

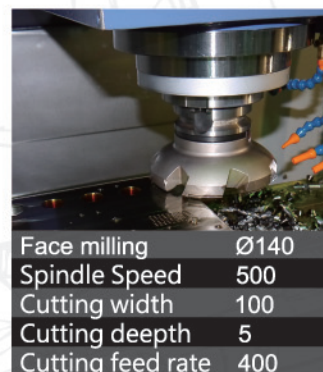

Face milling	Ø140
Spindle Speed	500
Cutting width	100
Cutting depth	5
Cutting feed rate	400

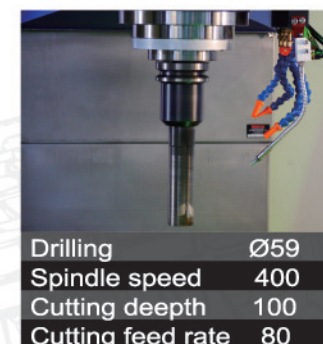

Drilling	Ø59
Spindle speed	400
Cutting depth	100
Cutting feed rate	80

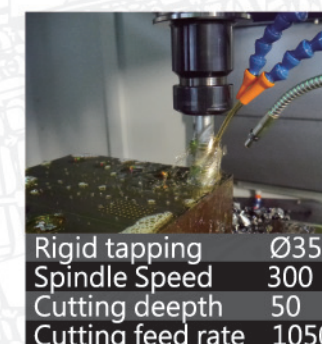

Rigid tapping	Ø35
Spindle Speed	300
Cutting depth	50
Cutting feed rate	1050

Strictly Quality Assurance

Cutting accuracy test measured up the Test conditions for machining centres – Part 7: Accuracy of a finished test piece.

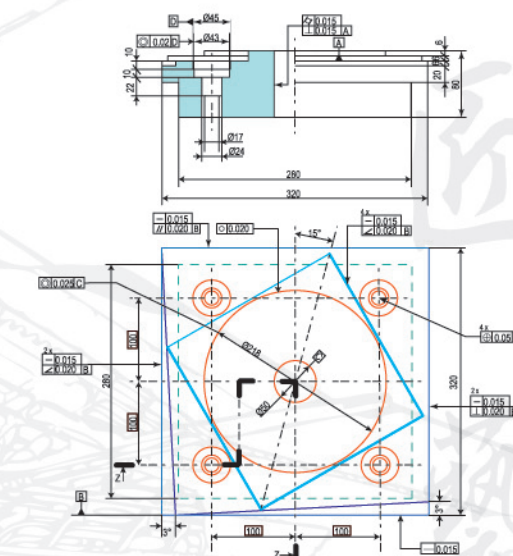

ISO/CD 10791-7
Test workpiece drawing

Precision Hand Scraped

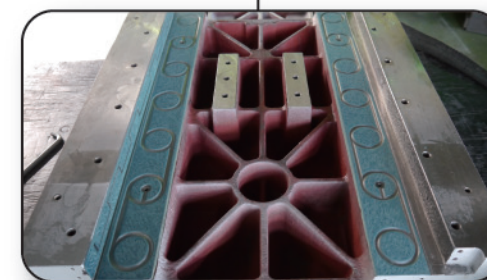

Hand scraped contact areas, minimal axis protection with maximum stroke.

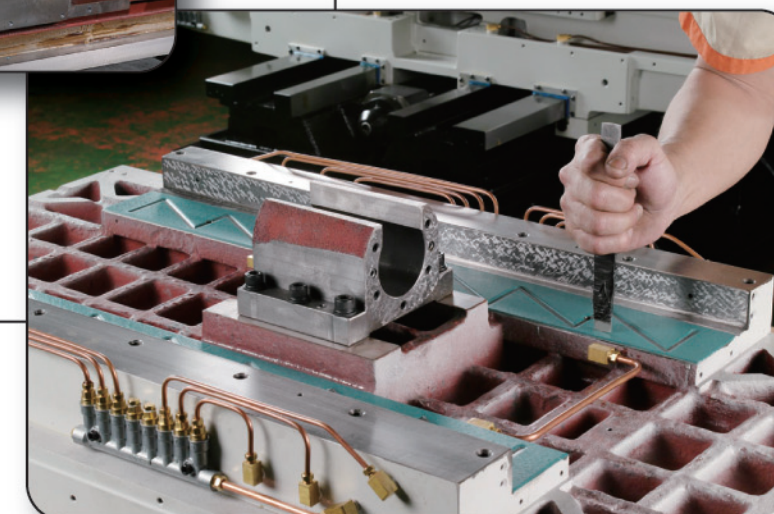

High Rigidity and High Precision Structure



The swivel operation box allows users to operate at suitable angle and position.

The wider width of door opening makes workpiece easier to be loaded and unloaded.



The design of tilting bed surface and flushing coolant system provides perfect performance of chip-removal.

- ◆ 3 axes travel: X=1000~3200mm · Y=510~1066mm · Z=560~750mm.
- ◆ Bed, column, saddle and other main castings are made of Meehanite grade cast iron and released the stress by heat treatment, ensuring the best structural stability and positioning accuracy.
- ◆ Box-shape bed is made of one piece casting iron.
V10~V20 are 4 box ways design (2 major ways and 2 supporting ways)
V22~V32 are 6 box ways design (4 major ways and 2 supporting ways).
The wider supporting space and high loading capacity provide the best structural rigidity and machining stability
- ◆ 3 axes ball screws pretension design reduces thermal deformation, offering the best accuracy.
- ◆ Absolute encoder motors are used in 3 axes feeding system to ensure the positioning accuracy.
- ◆ 3 axes ball screws and box ways are lubricated by centralized automatic lubrication system (oil type).
- ◆ Spindle oil cooling system reduces the effect of thermal deformation, providing the maximum heat dissipation capacity.
- ◆ The device of oil & coolant separation on machine bed and oil skimmer (optional) on coolant tank prolongs the service life of coolant.
- ◆ Fully enclosed splash guard provides safety and clean operating environment.

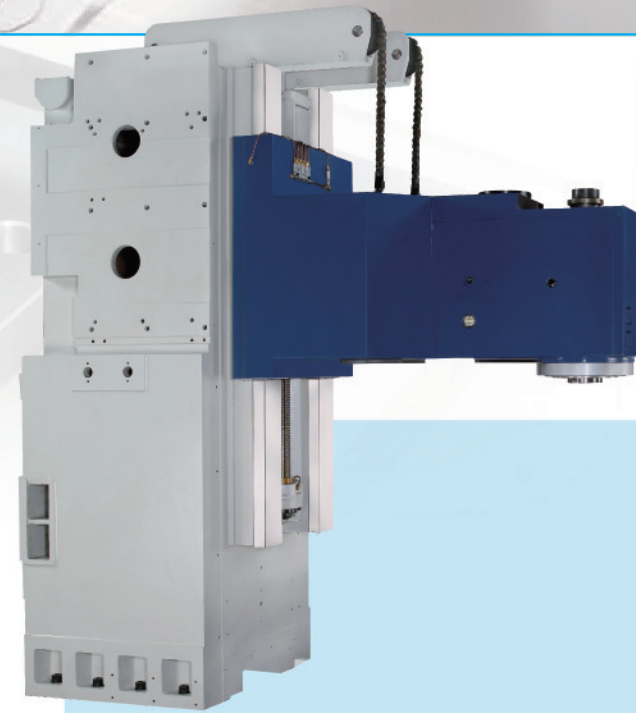

The designs of box-shape bed, wider supporting space between bed & column and counter-balanced spindle head provide the best structural rigidity and stable cutting performance.

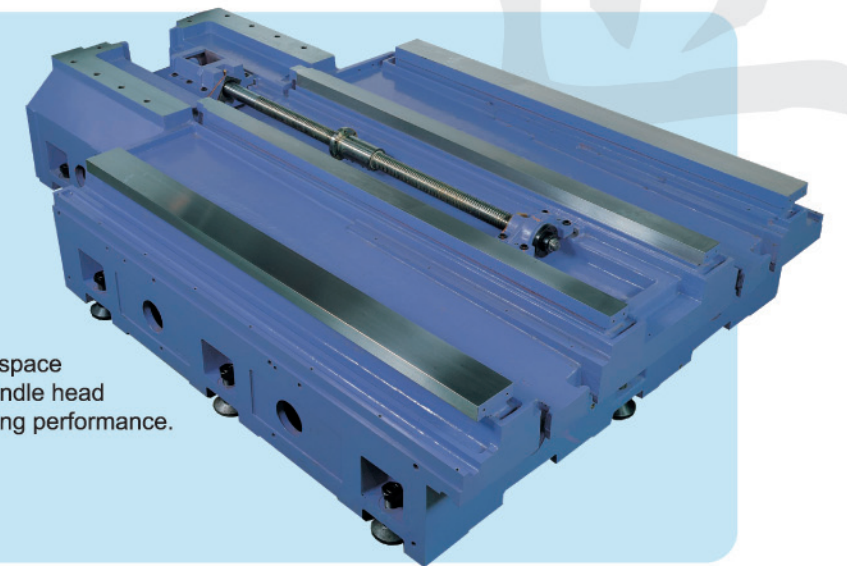

V10-V20 bed is 4 box ways design

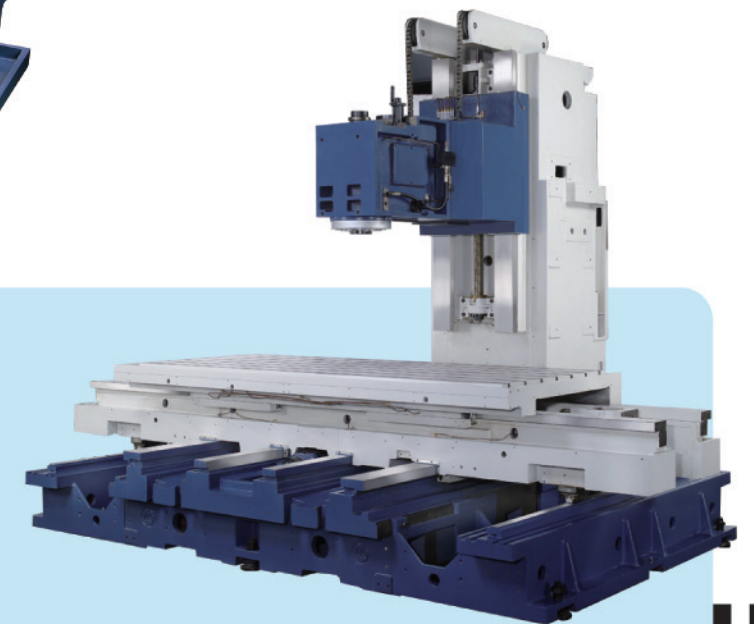

V22/V32 bed is 6 box ways design
4 major ways and 2 supporting ways

匠

藝

傳

承

匠

匠



High Accuracy and High Performance Spindle



■ Gear type spindle ■ Gear box ■ Belt type spindle

- ◆ V series provides gear type spindle and belt type spindle to meet different machining requirements. The spindle speed range is from 6,000 rpm to 12,000 rpm.
- ◆ Spindles are 100% manufactured by Takumi, featuring high accuracy and high performance.
- ◆ Spindle cooling system reduces thermal variation and prolongs working life of spindle.

Spindle Power & Torque Chart

■ Belt type, 7.5/11kW, 10000rpm (Standard: V10/V11/V12)

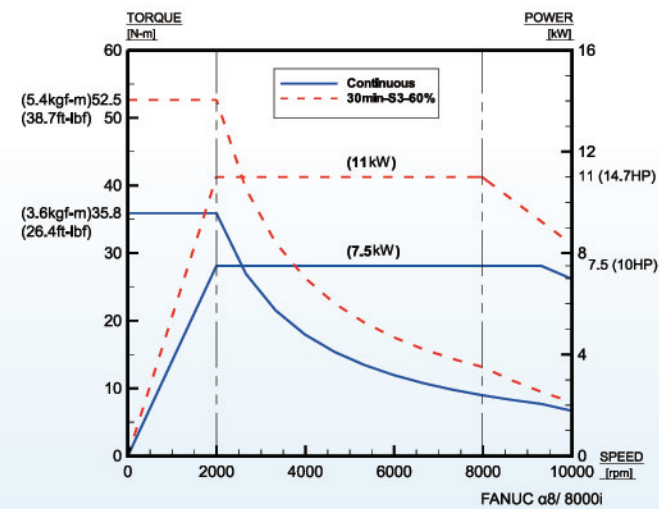

■ Belt type spindle, 9/11kW, 10000rpm (Optional)

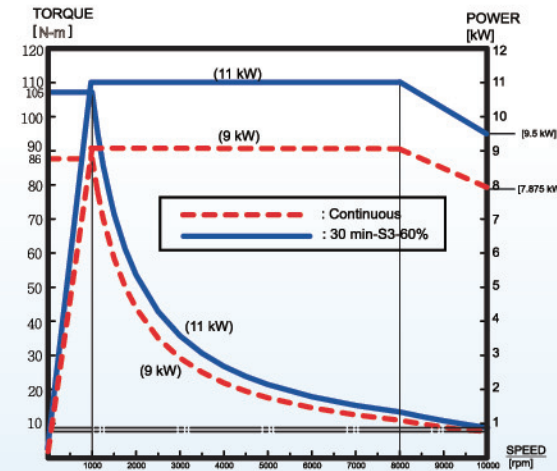

■ Gear type spindle, 15/18.5kW, 6000rpm (Standard: V15/V18/V20)

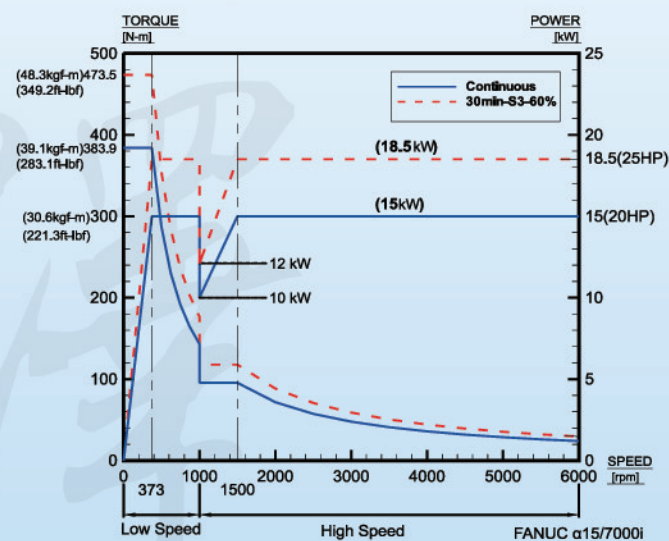

■ Gear type spindle, 22/26kW, 6000rpm (Standard: V22/32)

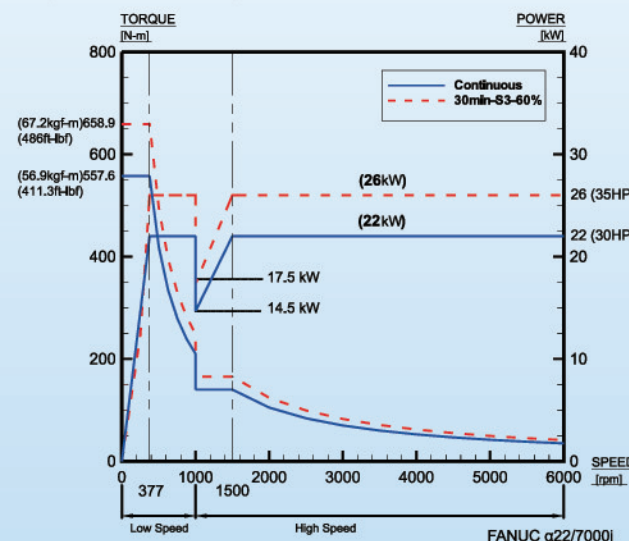

ATC

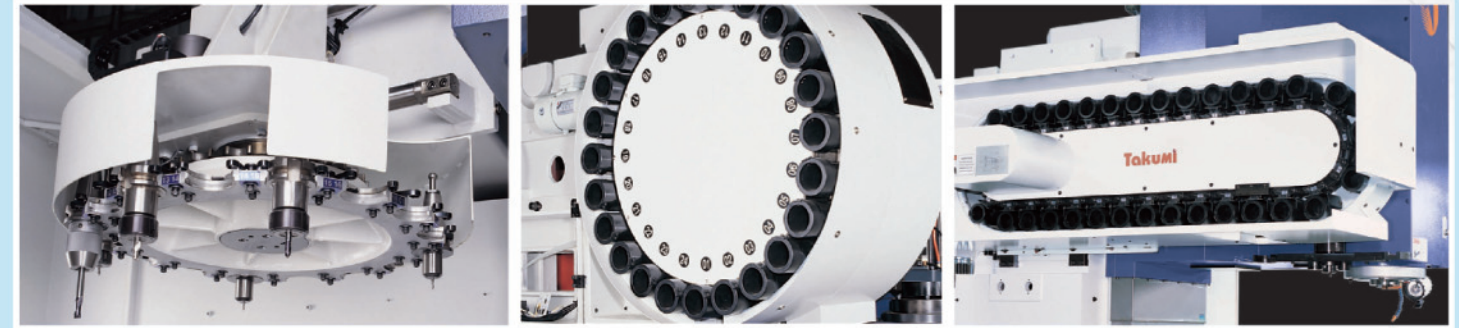

- Armless type ATC (Standard)
 - V10 : 16 tools/BT40
 - V12 : 20 tools/BT40
- Arm type ATC (Standard)
 - V15~V32 : 24 tools/BT50
- Arm type ATC (Optional)
 - V10~V12 : 32 tools/BT40
 - V15~V32 : 32 tools/BT50

Optional Accessories



- Workpiece measurement system
- Tool length measurement system
- Linear scales
- Chip conveyor
- Ball screw cooling system
- Coolant through spindle
- 4th axis rotary table
- Oil mist collector

ISO 9001:2008 Quality Management

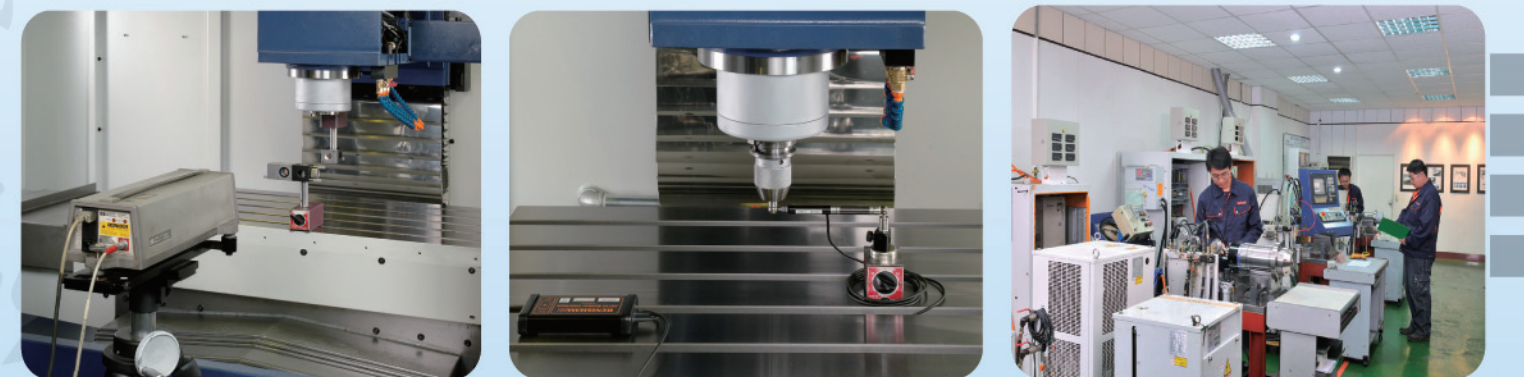

- Laser inspection
- Ball bar inspection
- Spindle test running

V10, V11, V12

Machine Dimension (mm)

	V10	V11	V12
A	4330	4720	5030
A1	2900	3050	3650
A2	1900	2115	2015
A3	2804	2800	3300
A4	940	1310	1107
B	4104	4400	4740
B1	2617	3615	3313
B2	2060	2260	2440
B3	1550	1670	1860
B4	770	835	725
C	2650	3150	2897
C1	2320	2465	2328
C2	2165	2340	2228
C3	765	840	970
C4	150-710	150-750	150-760
C5	815	945	800
C6	1720	1665	1600

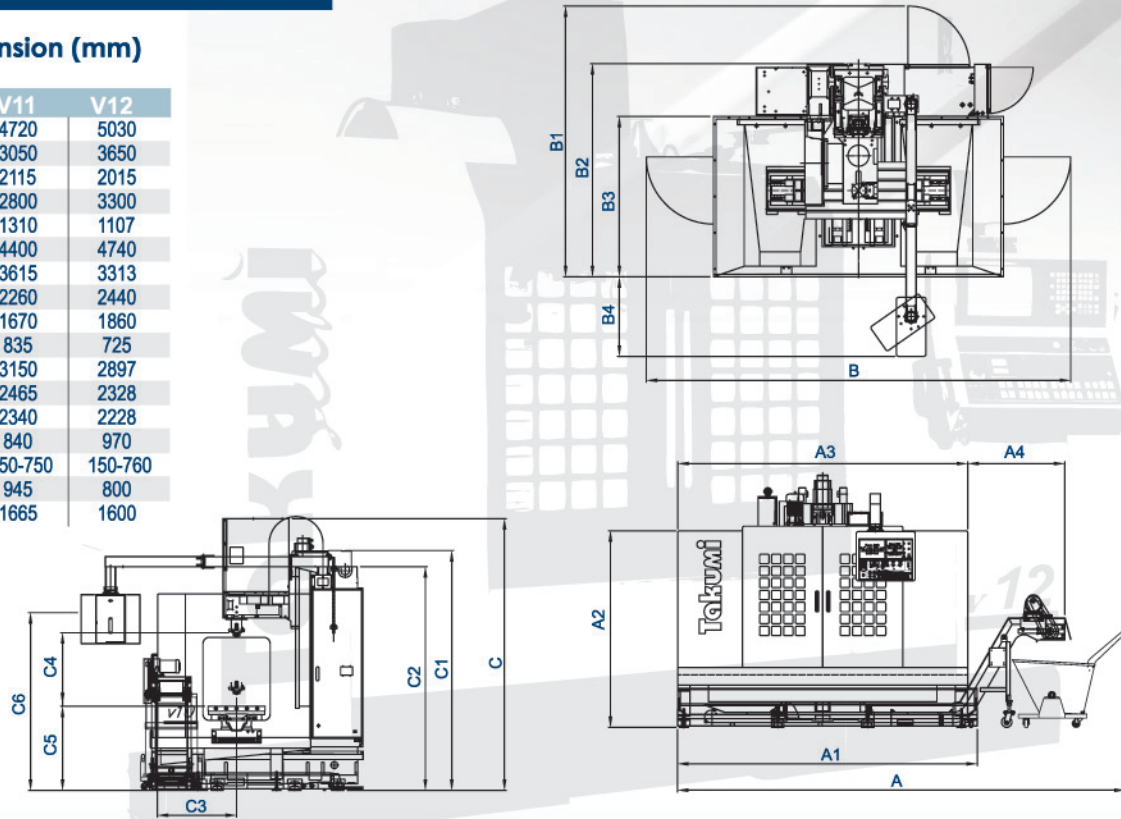

V22, V32

Machine Dimension (mm)

	V22	V32
A	5700	7500
A1/2	1400	1660
A3	1210	1171
A4	5070	7445
A5	1210	1171
B	4740	4690
B1	3960	3910
B2	3565	3500
B3	2780	2757
B4	955	1006
C	3510	3510
C1	3205	3205
C2	3113	3100
C3	2990	2990
C4	200-950	200-950
C5	990	990
C6	1900	1900

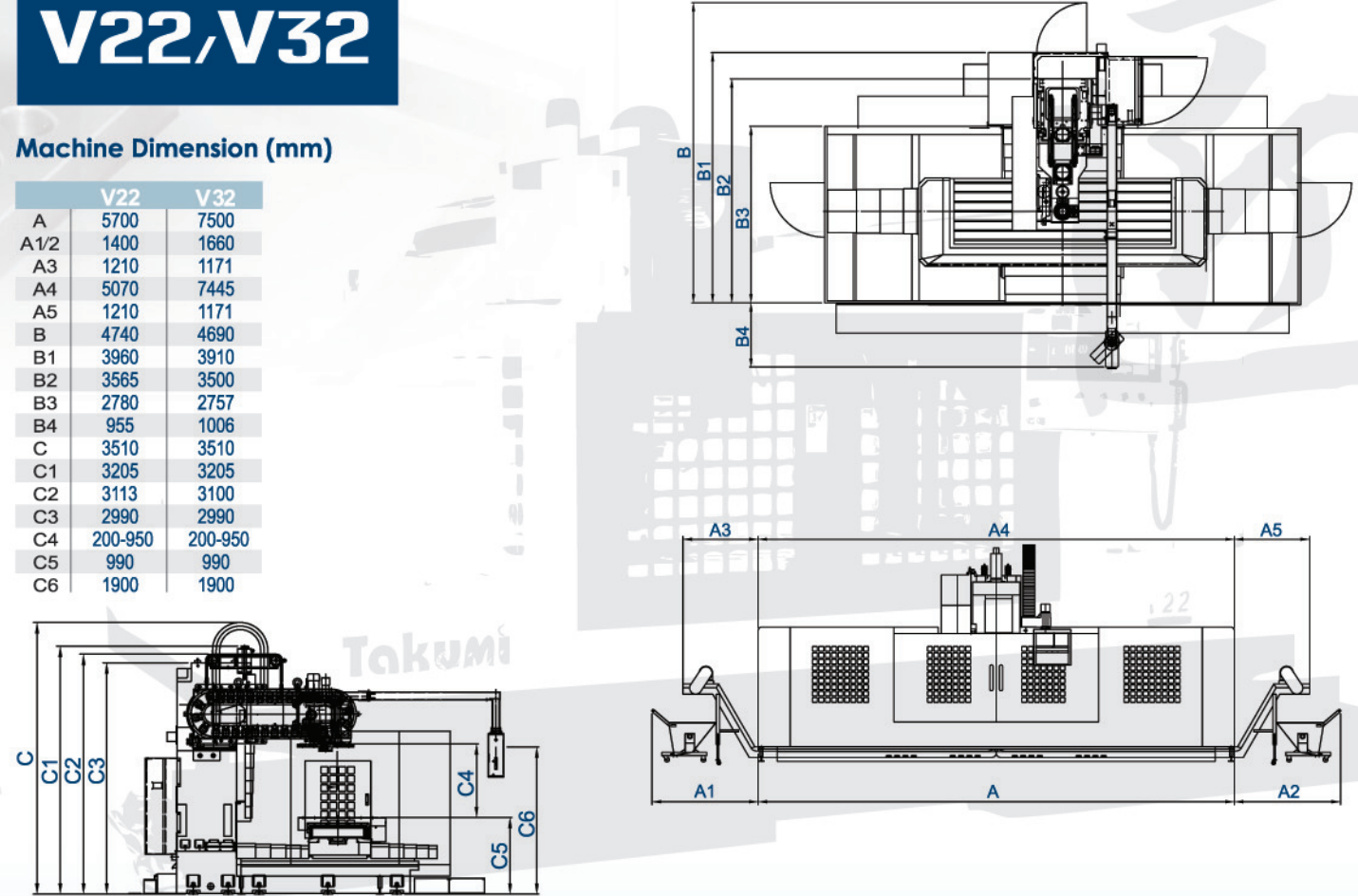

V15, V18, V20

Machine Dimension (mm)

	V15	V18	V20
A	5440	5877	5877
A1	4100	4547	4547
A2	2050	2095	2095
A3	3800	4447	4447
A4	995	915	915
B	5500	5147	6147
B1	3884	4100	3864
B2	2895	3314	3154
B3	2150	2525	2525
B4	1000	826	830
C	3256	3230	3220
C1	2998	2990	2980
C2	2793	2803	2793
C3	1135	1330	1330
C4	150-870	200-950	200-950
C5	925	910	910
C6	1755	1700	1823

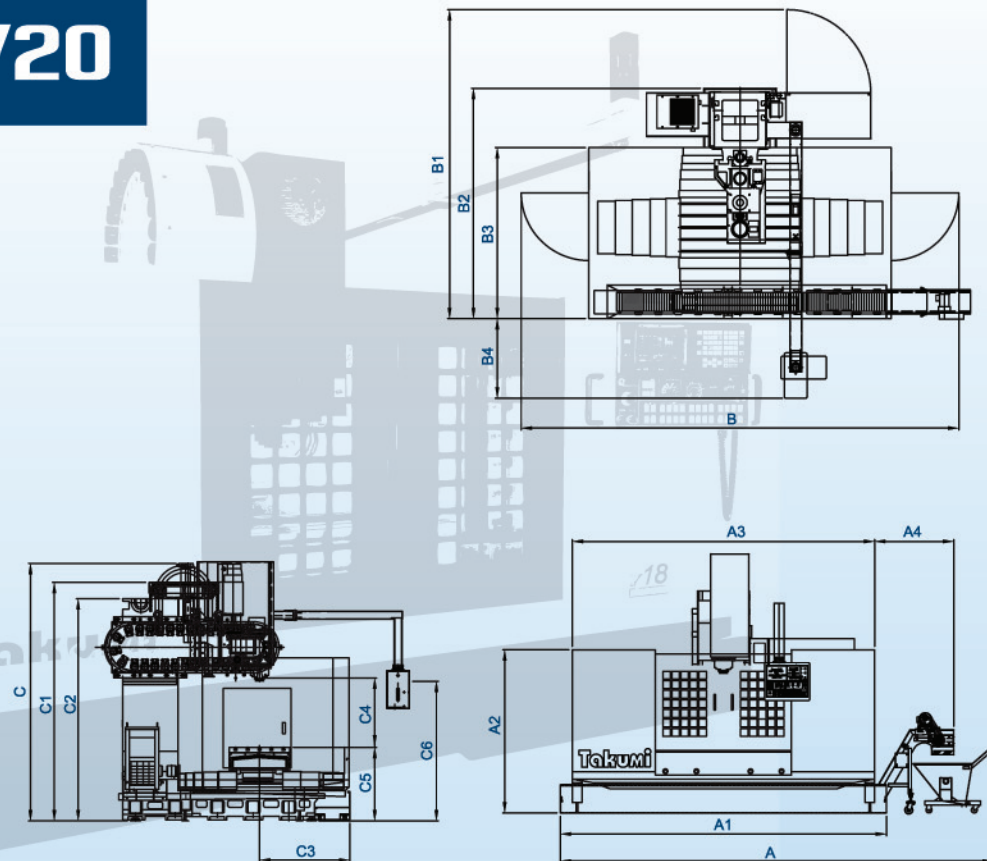
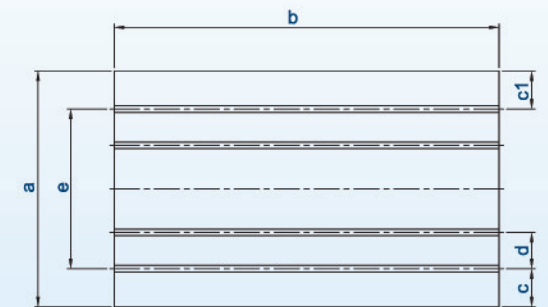
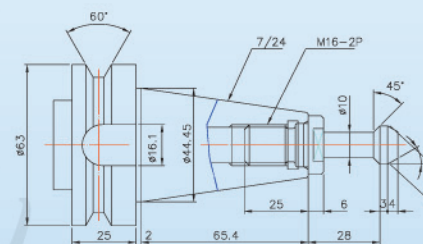

Table size & T-slot (mm)

	V10	V11	V12	V15	V18	V20	V22	V32
a	550	650	690	760	850	955	1025	1025
b	1060	1150	1350	1600	1900	2100	2200	3200
c	75	125	120	80	125	80	80	62.5
c1	75	125	70	80	125	125	125	62.5
d	100	100	125	150	150	150	150	150
e	5	5	5	5	5	6	7	7
f	30	30	30	38	38	38	41.5	41.5
g	18	18	18	22	22	22	22	22
h	30	30	30	37	37	37	37	37
i	12	12	12	16	16	16	16	16



Tool Shank and Pull Stud Dimension



TOOL SHANK: BT40
RETENSION STUD: MAS 1

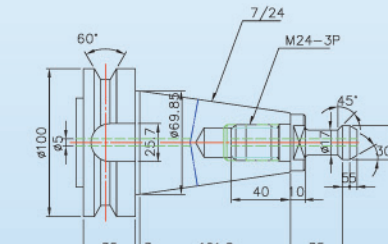

TOOL SHANK: BT50
RETENSION STUD: MAS 1

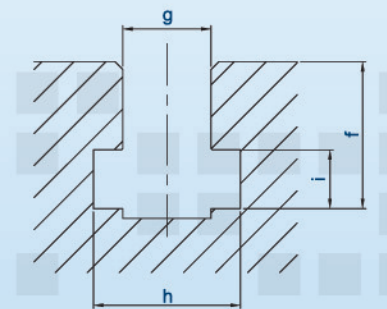

Specifications are subject to change without notice.

Specifications are subject to change without notice.

Specification

Travel	Unit	V10	V11	V12	V15
X axis	mm	1000	1100	1200	1524
Y axis	mm	510	650	660	762
Z axis	mm	560	600	610	720
Dist. from spindle nose to table	mm	150~710	150~750	150~760	150~870
Dist. from spindle nose to Z axis guide way	mm	570	700	695	820
Table					
Dimension	mm	1060 x 550	1300 x 650	1350 x 690	1600 x 760
Max. load	kg	600	1100	1100	1500
T-slot (width×pitch×number)	mm	18x100x5	18x125x5	18x125x5	22x150x5
Spindle					
Type	—	Belt	Gear	Belt	Gear
Spindle speed	rpm	10,000	6,000	10,000	6,000
Motor power (cont. /30 min)	kW	7.5/11	9/11	7.5/11	15/18.5
Spindle taper	—	BT40	BT50	BT40	BT50
Feed rate					
Rapid traverse (X/Y/Z)	m/min	20x20x18	20x20x14	20x20x14	16x16x12
Cutting feed rate	mm/min	1~7000	1~7000	1~7000	1~5000
Motor power (X/Y/Z)	kW	3.0/3.0/3.0	3.0/4.0/4.0	4.0/4.0/4.0	4.0/7.0/4.0
ATC & Magazine					
ATC type	—	Armless	Arm	Armless	Arm
Magazine Capacity	pcs	16	24	20	24
Max. tool diameter (next pocket empty)	mm	100/150	105/200	100/180	110/220
Max. tool length	mm	250	250	250	300
Max. tool weight	kg	7	15	7	15
Tool shank	—	BT40	BT50	BT40	BT50
Pull stud	—	MAS 407	MAS 407	MAS 407	MAS 407
Space & System Requirement					
Pneumatic pressure	kgf/cm ²	6	6	6	6
Electrical power consumption	kVA	30	35	35	35
Machine net wight	kg	6200	6800	7500	13000
Max. floor spece (W x L x H)	mm	2800x2210x2355	3200x2240x2940	3300x3150x2620	3835x3653x3241

Specifications are subject to change without notice.

Standard Accessories

- ◆ FANUC 0iMD controller
- ◆ 10000rpm, BT40, belt type spindle (V10/V12)
- ◆ 6000rpm, BT50, gear type spindle (V11/V15~V32)
- ◆ 16T, BT40, Armless type ATC (V10)
- ◆ 20T, BT40, Armless type ATC (V12)
- ◆ 24T, BT50, Arm type ATC (V11/V15~V32)
- ◆ Spindle air blast
- ◆ Cutting air blast
- ◆ Spindle cooler
- ◆ Cutting coolant system
- ◆ Centralized automatic lubrication system (oil)
- ◆ Fully enclosed splash guard
- ◆ Working lamp
- ◆ Indication lamp
- ◆ Washing gun & air gun
- ◆ Coolant tank & coolant flushing system
- ◆ Manual Pulse Generator (MPG)
- ◆ Ethernet & RS-232C interface
- ◆ Heat exchanger for electrical cabinet
- ◆ Tool kits
- ◆ Leveling blocks and bolts
- ◆ Operation manuals, PLC, electrical circuit diagrams
- ◆ One-year machine warranty (Spindle warranty depends upon spindle manufacturer)
- ◆ Controller warranty (FANUC : 24 months from shipping date)

Travel	Unit	V18	V20	V22	V32
X axis	mm	1800	2000	2200	3200
Y axis	mm	850	850	1066	1066
Z axis	mm	750	750	750	750
Dist. from spindle nose to table	mm	200~950	200~950	200~950	200~950
Dist. from spindle nose to Z axis guide way	mm	920	920	1120	1120
Table					
Dimension	mm	1900 x 850	2100 x 955	2200 x 1025	3200 x 1025
Max. load	kg	2000	2000	3000	4500
T-slot (width×pitch×number)	mm	22x150x5	22x150x6	22x150x7	22x150x7
Spindle					
Type	—	Gear	Gear	Gear	Gear
Spindle speed	rpm	6,000	6,000	6,000	6,000
Motor power (cont. /30 min)	kW	15/18.5	15/18.5	22/26	22/26
Spindle taper	—	BT50	BT50	BT50	BT50
Feed rate					
Rapid traverse (X/Y/Z)	m/min	15x15x12	15x15x12	12x12x12	10x10x10
Cutting feed rate	mm/min	1~5000	1~5000	1~5000	1~5000
Motor power (X/Y/Z)	kW	4.0/7.0/4.0	4.0/7.0/4.0	7.0/7.0/7.0	7.0/9.0/7.0
ATC & Magazine					
ATC type	—	Arm	Arm	Arm	Arm
Magazine Capacity	pcs	24	24	24	24
Max. tool diameter (next pocket empty)	mm	110/220	110/220	110/220	110/220
Max. tool length	mm	300	300	300	300
Max. tool weight	kg	15	15	15	15
Tool shank	—	BT50	BT50	BT50	BT50
Pull stud	—	MAS 407	MAS 407	MAS 407	MAS 407
Space & System Requirement					
Pneumatic pressure	kgf/cm ²	6	6	6	6
Electrical power consumption	kVA	45	45	50	50
Machine net wight	kg	16000	172000	19700	23850
Max. floor spece (W x L x H)	mm	4486x4213x3229	4680x4215x3240	5100x4405x3550	7500x4405x3550

Optional Accessories

- ◆ MITSUBISHI M70 controller
- ◆ 12000rpm, BT40, belt type spindle (V10~V12)
- ◆ 6000rpm, BT40, gear type spindle (V12)
- ◆ 6000rpm, BT50, gear type spindle (V12)
- ◆ 24T, BT40, arm type ATC (V10/V12)
- ◆ 32T, BT40/BT50, arm type ATC
- ◆ Coolant through spindle (20 BAR)
- ◆ Oil skimmer
- ◆ Oil mist device
- ◆ Oil mist collector
- ◆ Linear scales (3 axes)
- ◆ Workpiece measurement system
- ◆ Tool length measurement system
- ◆ The 4th axis rotary table
- ◆ Steel belt type chip conveyor
- ◆ Scraper type chip conveyor
- ◆ Transformer
- ◆ Coolant through tool adapter
- ◆ Tapping lubrication device
- ◆ CE (CE area only)

Specifications are subject to change without notice.

1.All data listed here are based on machines with standard accessories. Data will be altered according to different options. For detailed information, please refer to local agents or Takumi sales.
2.Takumi reserves the rights on the modifications of the machine specifications.